

Line Interactive Pure Sinewave UPS User's Manual

750/1000VA, 1500/2000VA, 3000VA Series

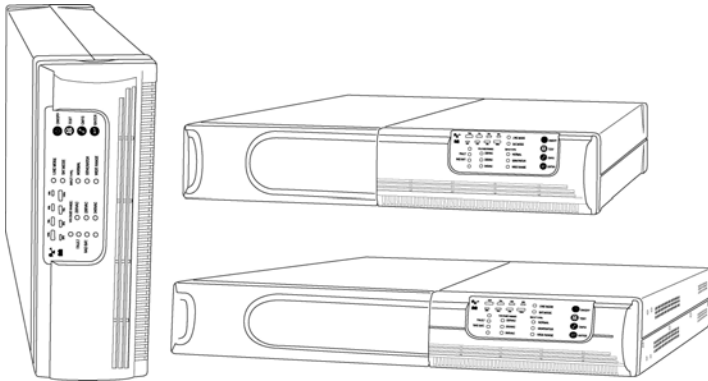

Uninterruptible Power System

IMPORTANT SAFETY INSTRUCTIONS

SAVE THESE INSTRUCTIONS – This manual contains important instructions for 750/1000VA, 1500/2000VA, 3000VA series that should be followed during installation and maintenance of the UPS and batteries. Please read all safety and operating instructions before operating the UPS. Adhere to all warnings on the unit and in this manual. And follow all operating and user instructions.

CONTENTS

1. INTRODUCTION	1
2. SAFETY INSTRUCTION – CAUTION	2
3. SYSTEM DESCRIPTION	4
4. INSTALLATION	13
5. ADDITIONAL BATTERY INSTALLATION SETUP	23
6. BATTERY REPLACEMENT	28
7. COMMUNICATION PORT	28
8. TROUBLE SHOOTING	29
9. SPECIFICATION	30
10. SOFTWARE INSTALLATION	31

1. INTRODUCTION

This series is a compact and fully pure sinewave line interactive UPS, and it designs for critical application and environment, such as desktops, servers, workstations, and other networking equipments. This model is available in the output ratings of 750, 1000, 1500, 2000, and 3000VA. This series protects your sensitive electronic equipments against power problems including power sags, spike, brownouts, line noise, and blackouts.

This series designs from two-in-one form factor; it can be placed either in Rack 2U or Tower. The front panel of the UPS includes LED indicators and four push buttons (Power Switch, UPS Test/Silence, Configure, and Enter) that allow to monitor easily, configuration and control, AC line-in, notification of site wiring fault and output load status of the UPS. It also includes four LED bar graphic (Load/Battery Level Indication); two status indications (On AC, On Battery); five alarm indications (Overload, Over Temperature, Site Wiring Fault, Battery Fault, Self Test Failure). A push button from the front panel allows silencing of the AC fail alarm and the initiation of the UPS self test sequence as well. The UPS case for 750 ~ 2000VA is made of plastic as well as 3000VA is made of metal.

This series is powered from the AC mains and supply AC outputs via receptacles on the rear panel. Communication and control to the unit is available through serial or USB ports located on the rear panel. The serial port will support communications directly with a server. The communications protocol for the serial ports shall conform to true RS232 interface.

Features:

- Microprocessor control guarantees high reliability
- High frequency design
- Built-in boost and buck AVR
- User replaceable design for 1500VA or above
- Selectable output range and line sensitive
- Cold startup capability
- Built-in Dry contact/RS-232/USB communication port
- SNMP allows for web-based remote or monitoring management
- Enable to extend runtime with scalable external battery pack for 1500VA or above
- Overload, Short-circuit, and overheat protection
- Rack/Tower 2 in 1 Design
- 19" rack mount available for all models

2. SAFETY INSTRUCTION – CAUTION

IMPORTANT SAFETY INSTRUCTIONS

SAVE THESE INSTRUCTIONS - This Manual Contains Important Instructions that should be Followed during Installation and Maintenance of the UPS and Batteries.







WARNING: Do not attempt to repair and service this UPS. This UPS contains high voltages which could cause the risk of electrical shock. Even this UPS is disconnected from the electrical outlet, the dangerous voltage still may be present through the battery. All maintenance and battery replacement should be performed by qualified service personnel only.

1. This UPS should be placed indoors with adequate airflow and free of contamination. To install or operate it in a clean and indoor environment, free from moisture, flammable liquids, and direct sunlight. Ambient temperature range must be 0°C to 40°C (32°F to 104°F).
2. This UPS is designed for Commercial/Industrial use only. It is not intended for use with life support application and other designated “life-critical” devices.
3. Do not remove the input power cord when this UPS is turned on. This removes the safety ground from this UPS and the equipment connected to the UPS.
4. Turn off this UPS and disconnect input power cord before battery replacement.
5. Battery contains high short-circuit current. Replacing or servicing the battery which should be performed and supervised by qualified service personnel knowledgeable of batteries and required precautions.
 - Remove watches and jewelries
 - Use tools with insulated handles
 - Wear rubber gloves and boots.
 - Do not lay tools or metal parts on top of batteries.
 - Disconnect charging source prior to connecting or disconnecting battery terminals.
6. When replacing the batteries, use the appropriate replacement battery kits, same number and type of battery are **MUST**.
7. Do not open or mutilate the battery. Released electrolyte is harmful to skin and eyes that may be toxic.
8. Do not dispose of battery in a fire. Battery may explode. Proper disposal of battery is required. Please refer to your local laws and regulations for disposal requirements.

2. SAFETY INSTRUCTION – CAUTION

9. To reduce the risk of fire, use only No. 26 AWG or larger telecommunication line cord.
10. This UPS contains high voltages which may cause the risk of electric shock. Do not remove cover. There are no user replaceable parts inside this UPS. Please contact your local dealer or distributor for service.
11. To reduce the risk of fire, connect to a circuit provided with 30 amperes maximum (for 3000VA) and 20 amperes maximum (for 2000VA and below models) branch circuit over-current protection in accordance with the National Electric Code, ANSI/NFPA 70.
12. This pluggable type A equipment with battery already installed by the supplier is operator installable and may be operated by laymen.
13. During the installation of this equipment it should be assured that the sum of the leakage currents of the UPS and the connected loads does not exceed 3.5mA.
14. Attention, hazardous through electric shock. Also with disconnection of this unit from the mains, hazardous voltage still may be accessible through supply from battery. The battery supply should be therefore disconnected in the plus and minus pole of the battery when maintenance or service work inside the UPS is necessary.
15. The mains socket outlet that supplies the UPS shall be installed near the UPS and shall be easily accessible.

2.1 Description of Commonly Used Symbols

Symbol & Description	
Symbol	Description
	Alert you to pay special attention
	Caution of high voltage
	Alternating current source(AC)
	Direct current source(DC)
	Protective ground
	Recycle
	Keep UPS in a clear area

3. SYSTEM DESCRIPTION

Front Panel —

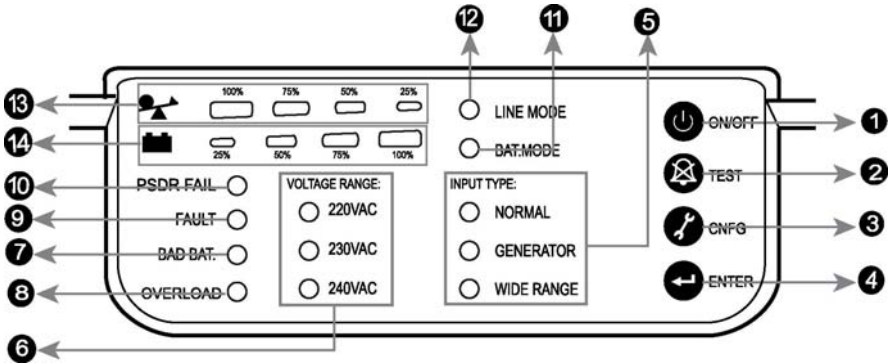

No.	Function	Description
1	Switch	ON/OFF
2	Switch	Self-Test/ Alarm Silence
3	Switch	Config
4	Switch	Enter
5	LED	Input Type(Operating Mode)
6	LED	Voltage Range
7	LED	Bad Battery
8	LED	Overload
9	LED	Fault
10	LED	PSDR Fail (or Site Fault)
11	LED	Battery Mode
12	LED	Line Mode
13	LED	Capacity of Load
14	LED	Capacity of Battery

1. Power Switch:

- To turn on the UPS, press the  button more than three seconds.
- To turn off the UPS, press and hold this button until you hear the UPS beep ceases.

2. UPS Test/ Alarm Silence:

- The battery is fully charged during in line mode. To perform self-test function, press and hold the  button for five seconds.
- To disable alarm buzzer, press this button for a second that will turn off the

3. SYSTEM DESCRIPTION

alarm buzzer. Each time a new alarm event is encountered the alarm that will sound and press this button to turn off the alarm.

Note: Unable to disable alarm buzzer as below conditions: Low Battery, Overload, Fan Failed, Fan Fault Time Out, Over Temperature.

3. Configure:

To reconfigure the internal UPS setup options, follow the procedure as below:

Step 1: Press the Configure  button more than three seconds. Then UPS will transfer from configure mode to “output voltage mode”.

Step2: Press the Configure  button more than one second, the UPS allows you to select the “output voltage mode” one by one.

Step3: After selecting the mode, press the Enter  button more than three seconds, the “output voltage mode” is configured.

Step4: UPS will automatically transfer from configure mode to “operating mode”.

Step5: Press the Configure  button more than one second; the UPS will allow you to select the “operating mode” one by one.

Step6: After selecting the mode, press the  button more than three seconds, the “operating mode” is configured.

4. Enter:

Press the  button after you choose the mode.

5. Input Type (Operating Mode) LED:

INPUT TYPE:

- NORMAL
- GENERATOR
- WIDE RANGE

- Normal mode: The Yellow LED indicator will illuminate during normal mode, the UPS accepts AC input voltage range from +/-20%.
- Generator: No change to voltage window. However, the low frequency transfer point is changed to 40Hz and there is no limitation for high frequency transfer point.
- Wide range: The LED indicator will illuminate, the UPS accepts AC input voltage range from -30% ~ +20%.

3. SYSTEM DESCRIPTION

6. Voltage Range (Output Voltage Mode) LED:

UPS Output voltages selection: 110VAC/120VAC/127VAC or 220VAC/230VAC/240VAC.

VOLTAGE RANGE:

110VAC

120VAC

127VAC

VOLTAGE RANGE:

220VAC

230VAC

240VAC

7. Bad Battery LED:

The LED indicator will light on when the battery is failed or if the battery is disconnected, LED will flash every two seconds. Please check your battery connection; replace the battery or contact your local dealer for a battery replacement kit.

8. Overload LED:

The LED indicator will light on when the UPS overload timeout.

9. Fault LED:

The LED indicator will light on when the UPS fails/overload is timeout /or short-output.

10. PSDR FAIL LED(or SITE FAULT LED):

- PSDR FAIL LED: the LED indicator will light on when the power module of UPS fails.
- SITE FAULT LED: the LED indicator will light on when UPS is plugged into an improperly utility

Note: "SITE FAULT" function is only available for 120Vac models.

11. BAT Mode LED (Battery Mode):

The LED indicator will flash every five seconds when the UPS is providing battery power to your equipment. On the other hand, the LED indicator gives you a warning which will flash every two seconds when the battery is low.

12. Line Mode LED:

The line LED indicator illuminates when the AC source is present.

13. Capacity of Load LED:

- **Load Indicator:** The  LED indicator and the load level indicator will illuminate to show the load level.
- **Load Level Indicator:**

25%

50%

75%



100%

3. SYSTEM DESCRIPTION

There are four LED bar graphic to indicate the percentage of UPS load capacity which is being used by the protected equipment. The greater the load, the more LED indicators that will be illuminated. Each LED indicator designates a 25% of the UPS output capacity. Please see the following load level respectively.

- ◆ 0 ~ 25%: 1st LED indicator
- ◆ 26% ~ 50%: 1st and 2nd LEDs indicator
- ◆ 51% ~ 75% : 1st, 2nd, and 3rd LEDs indicator
- ◆ 76% ~ 100%: All of four LED indicators will illuminate

14. Capacity of Battery LED:

- **Battery Indicator:** The  LED indicator and battery level indicator will illuminate to show battery level.
- **Battery Level Indicator:**



There are four LED bar graphic to indicate the amount of battery capacity remaining. The higher the battery capacity, the more LED indicators that will be illuminated. Each LED indicator designates a 25% capacity level. Please see the following capacity level respectively.

- ◆ 0 ~ 25%: 4th LED indicator
- ◆ 26% ~ 50%: 3rd and 4th LEDs indicator
- ◆ 51% ~ 75% 2nd, 3rd, and 4th LEDs indicator
- ◆ 76% ~ 100%: All of four LED indicators will illuminate

Indicator Condition —

Condition	Alarm
Utility Mode(AC Mode)	Line LED Lighting
Backup Mode(Power Failure)	Flashing every four seconds
Site Fault	Site fault LED lighting (For 120VAC Models)
	4 segment LED bar: 0~25%: 4 th LED lighting; 26~50%: 3 rd and 4 th LEDs lighting; 51~75%: 2 nd , 3 rd , and 4 th LEDs lighting; 76~100%: all of 4 LEDs lighting
UPS Fault	Fault LED lighting
Overload	Overload LED lighting
Low Battery	Battery LED flashing every second

Audible Alarm Condition —

Condition	Alarm
Backup Mode(Power Failure)	Sounding every four seconds
Low Battery	Sounding every second
UPS Fault	Continuously Sounding
Overload	Sounding every second
Battery Replacement	Sounding every second

Back Panel -

750/1000VA

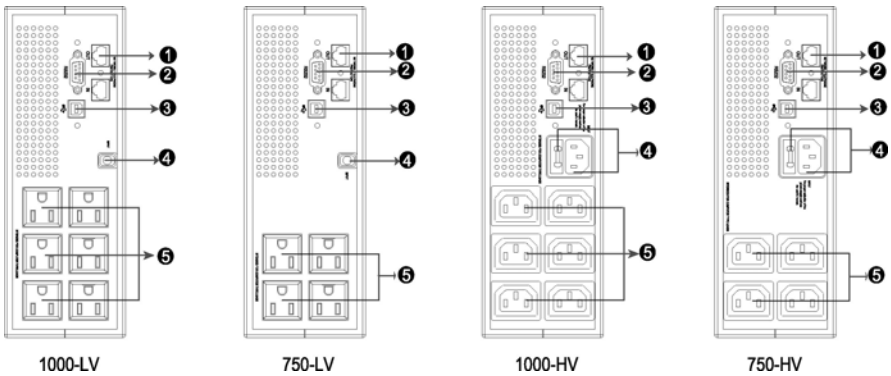

Rear panel description for LV and HV models table

No.	Function	
	LV model (110/120/127Vac)	HV model (220/230/240Vac)
1	Modem/Network Surge Protection	
2	RS232 / Dry-Contact Communication Port	
3	USB Communication Port	
4	AC Input Power cord	AC Input & Protection
5	AC Output NEMA	AC Output IEC

3. SYSTEM DESCRIPTION

1500/2000VA

1. Host Rear Panel:

The host rear panel pictures for HV and LV models are shown as below:

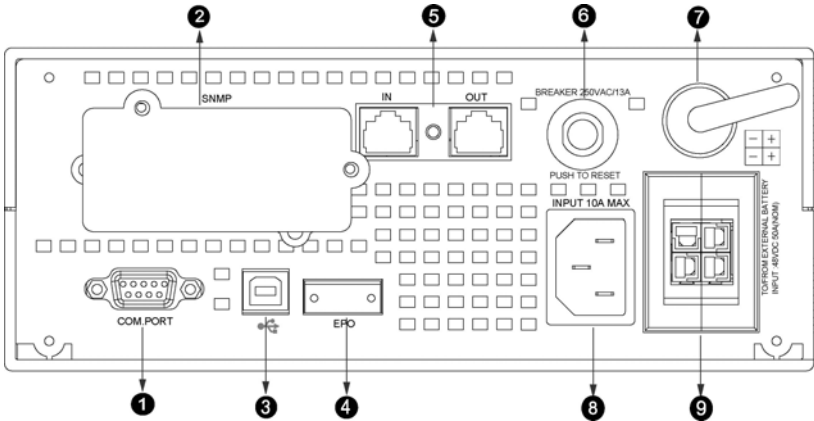

Host Rear panel for HV model

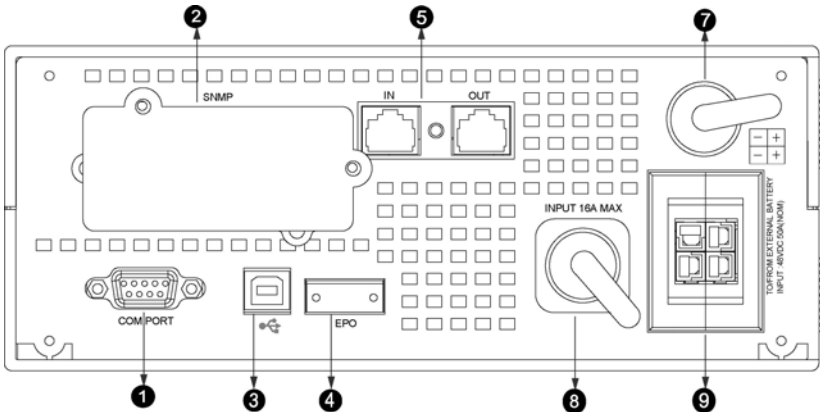

Host Rear panel for LV model

3. SYSTEM DESCRIPTION

Rear panel description for LV and HV models table

No.	Function	
	LV model (110/120/127Vac)	HV model (220/230/240Vac)
1	RS232 / Dry-Contact Communication Port	
2	SNMP Port	
3	USB Port	
4	EPO	
5	Modem/Network Surge Protection	
6	N/A	Input Breaker
7	AC Output	
8	AC Input	AC Input
9	External Battery Connector	

2. EBM Rear Panel:

The EBM rear panel pictures for HV and LV models are shown as below:

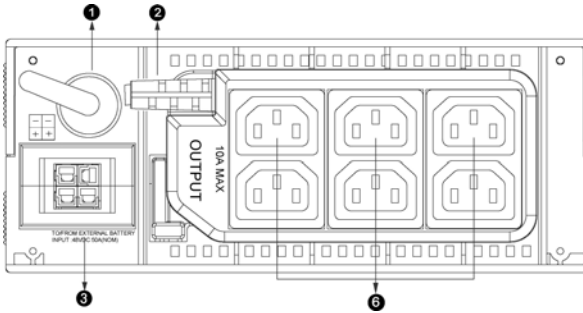

EBM Rear panel for HV model

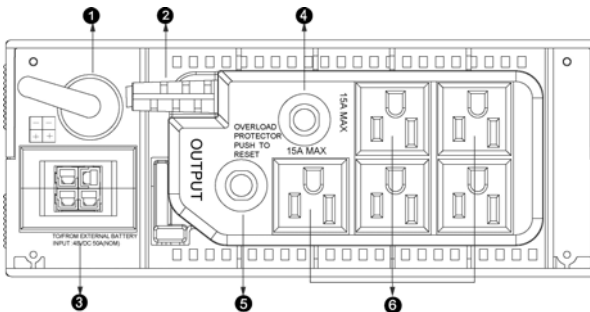

EBM Rear panel for LV model

3. SYSTEM DESCRIPTION

Rear panel description for LV and HV models table

No.	Function	
	LV model (110/120/127Vac)	HV model (220/230/240Vac)
1	Battery Output Power Cord	
2	AC Output	
3	External Battery Connector	
4	Output Breaker	N/A
5	Output Breaker	N/A
6	Output Receptacles	Output Receptacles

3000VA

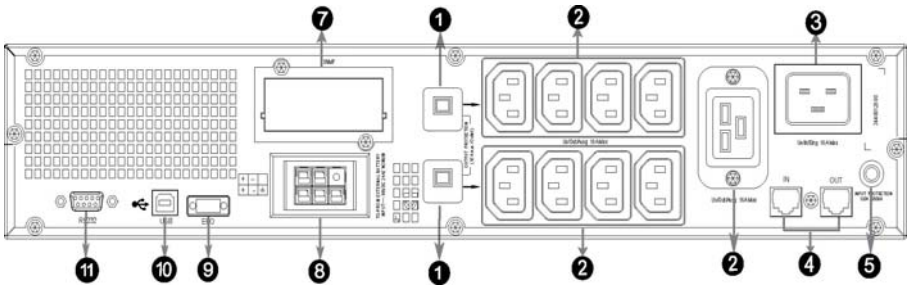

Rear panel for HV model

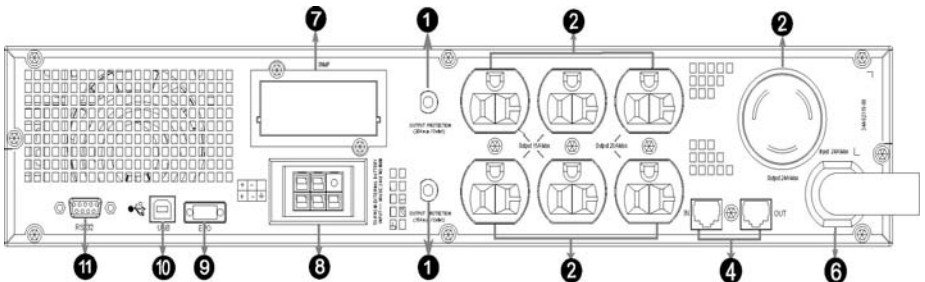

Rear panel for LV model

3. SYSTEM DESCRIPTION

Rear panel description for LV and HV models table

No.	Function	
	LV model (110/120/127Vac)	HV model (220/230/240Vac)
1	Output Breaker	
2	AC Output	
3	N/A	AC Input
4	Modem/Network Surge Protection	Modem/Network Surge Protection
5	N/A	Input Breaker
6	Input Power Cord	N/A
7	SNMP Slot	SNMP Slot
8	External Battery Connector	External Battery Connector
9	EPO	EPO
10	USB Port	USB Port
11	RS232 / Dry-Contact Communication Port	

4. INSTALLATION

1. Inspecting the Equipment

Inspect the UPS upon receipt. If the UPS has been damaged during shipment, keep the box and packing material for the carrier. Notify the carrier and dealer immediately.

2. Placement

This UPS should be installed indoors with adequate airflow and free of contamination. Locate it in a clean and indoor environment, free from moisture, flammable liquids, and direct sunlight. Maintain a minimum clearance of 4 inches (100mm); an ambient temperature range must be 0°C to 40°C (32°F to 104°F), and operating humidity range must be 20% to 80% relative humidity (non-condensing).

CAUTION: The long term uses at ambient temperature in higher than 25°C which should reduce battery life. In addition, place the UPS unit away from the monitor at least 20cm to avoid interference.

3. Charging

This UPS is shipped from the factory with its internal battery fully charged; however, some charge may be lost during shipping. The battery should be recharged prior to use. Plug the UPS into an appropriate power supply and allow the UPS to charge at least 4 hours.

4. Load Connection

Connect one load-related device to each of the power receptacles supplied at the rear of the UPS.

5. Modem/Phoneline Connection

Plug incoming telephone line into the “In” socket at the back of the UPS. Use on telephone line cable and plug one end of the telephone line cable to the “Out” socket at the back of the UPS. Plug the other end to the modem input socket.

6. DC Start Function

DC Start Function enables UPS to be started up when AC utility power is not available and battery is full charged. Just simply press the On/Off switch to turn on the UPS.

7. Turn On/Off

To turn on/off the UPS, you should press the on/off switch three seconds at least.

4. INSTALLATION

8. UPS Setup

All models series are designed for tower and rack purpose. They can be installed as a 19 inch equipment rack, and 3000VA can be placed in a tower (with optional stand) as well. Please follow the instruction for Tower Setup or Rack-Mount Setup.

9. Tower Setup

This series can be placed in horizontally and vertically. 3000VA model is designed in a rack itself. As a tower, it is provided with the optional UPS stand to stabilize the UPS when the UPS is positioned in vertically. The UPS stand must be attached to the bottom of the tower.

750/1000VA

- Tower form

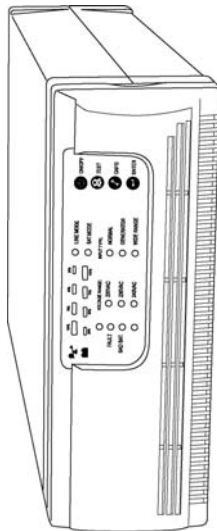

4. INSTALLATION

1500/2000VA

- Host and EBM integrate into three types of tower forms

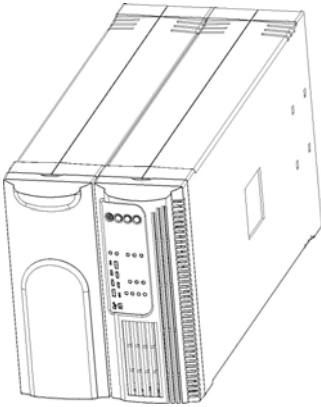

(a) Tower form 1

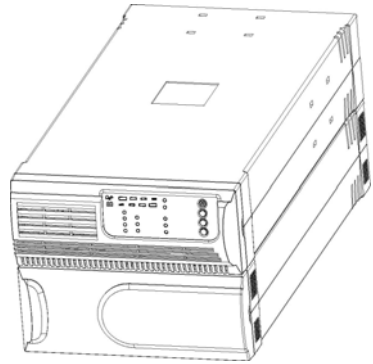

(b) Tower form 2

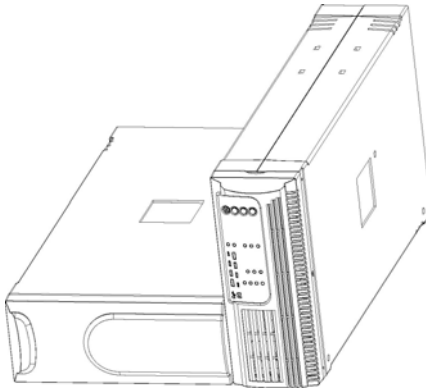

(c) Tower form 3

4. INSTALLATION

3000VA

- **Tower form setup**

1. Slide down the UPS vertically and put two UPS stands at the end of the tower.

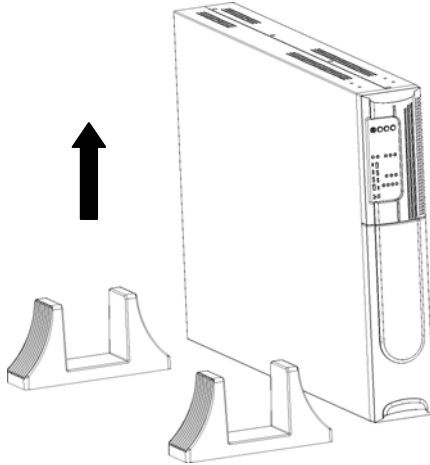

2. Place the UPS into two stands carefully.

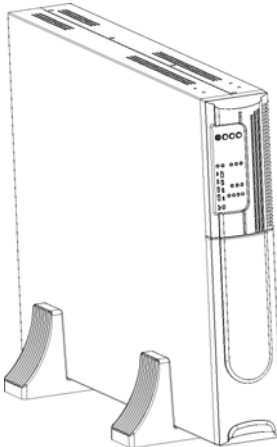

4. INSTALLATION

10. Rack-Mount Setup

750/1000/1500/2000VA(optional) and 3000VA can be installed in 19" racks. And the UPS and external battery enclosure need 2U of valuable rack space. Use the following procedure to install UPS in a rack.

750/1000VA(optional)

1. Align the mounting ears with screw holes on the side of the UPS.

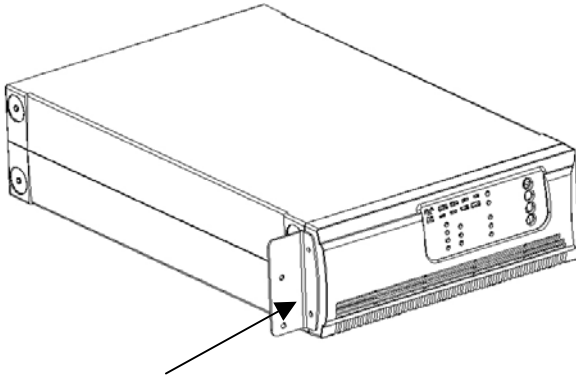

2. Install rack-mounting rails with the screws provided tightened up into rack enclosure.

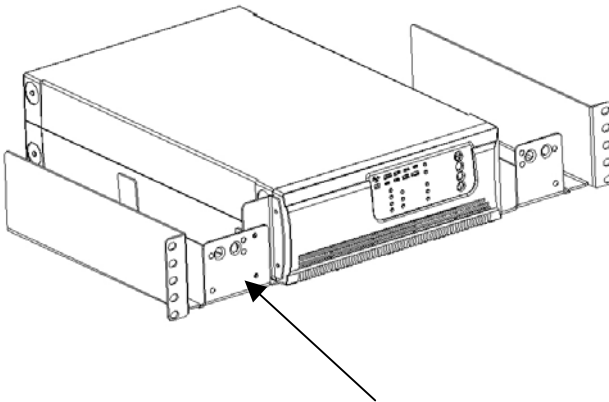

4. INSTALLATION

3. Insert UPS into the slide assemblies and lock it in the rack enclosure.

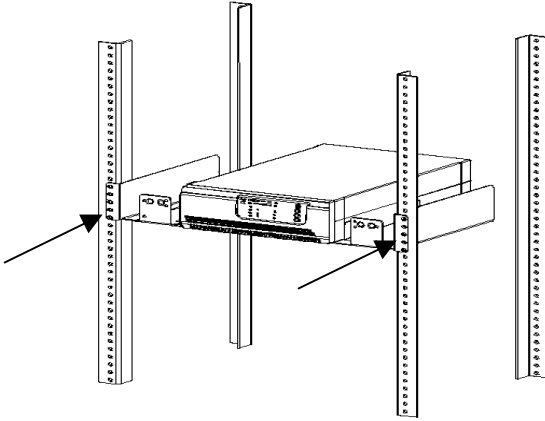

4. Add up the front panels for both sides. The load can be connected.

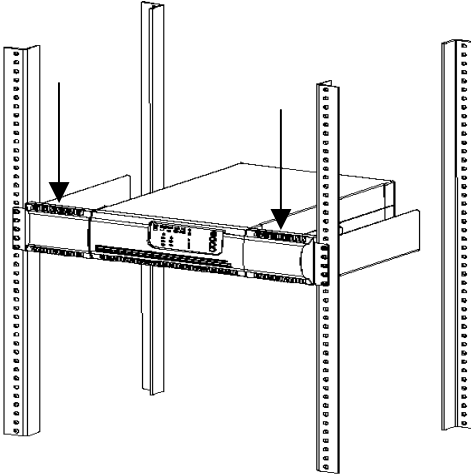

4. INSTALLATION

1500/2000VA(optional)

- **HOST and EBM integrate into a rack form**

1. Place the UPS on a flat and in a clean place that the front side of the UPS is facing to you.
2. Disconnect the cable from the Host and EBM.

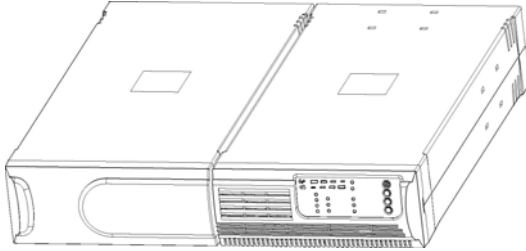

HOST and the EBM are disconnected

3. Loosen the screws and remove the Host and EBM cover from the unit

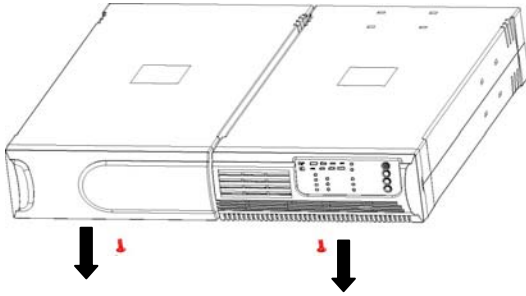

4. Pull two covers toward the direction shown as below.

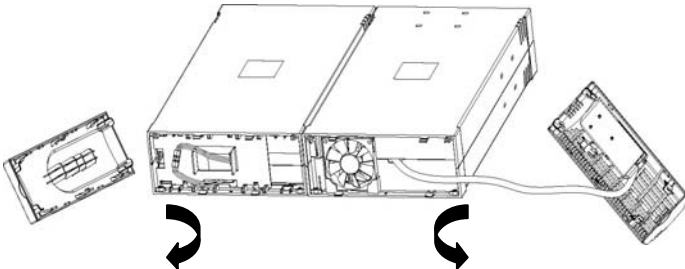

4. INSTALLATION

5. Align the mounting bracket with the screw holes on the each side of Host and EBM and secure with the supplied screws.

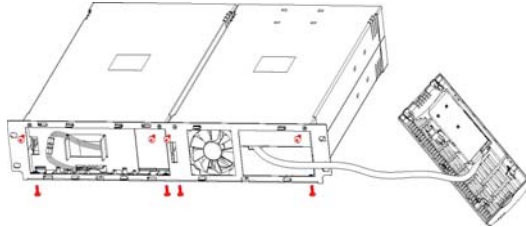

6. Reinstall the Host and EBM cover.

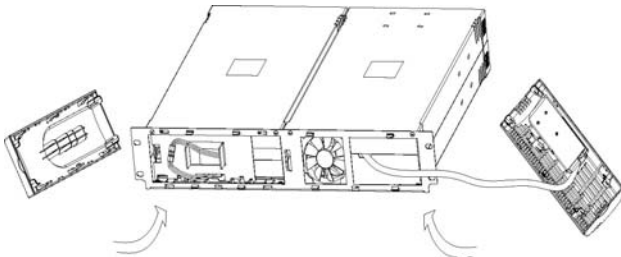

7. Tighten all screws up to front panels and setup rack-mount for front side is completed

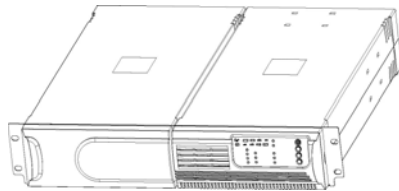

8. Align two small mounting brackets at the rear of Host and EBM and secure with the supplied screws. Install Output receptacles at the rear panel of the Host.

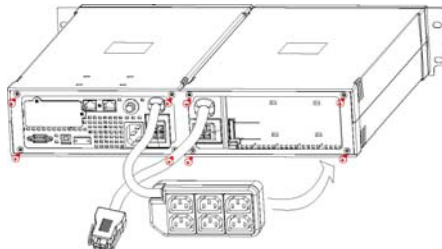

4. INSTALLATION

9. Setup rack-mount is completed and to connect the UPS

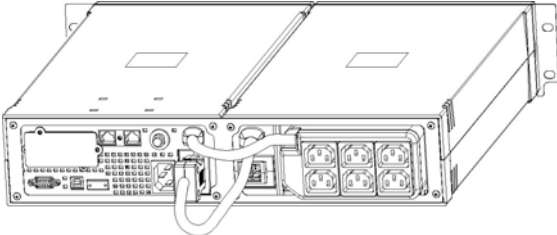

- **EBM and EBM integrate a rack form**

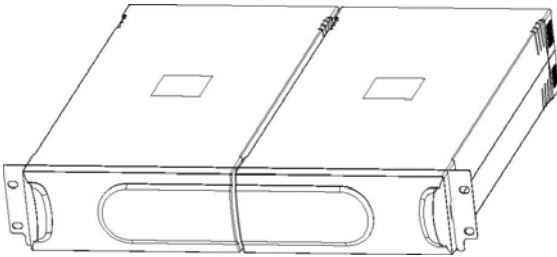

Remark : The rackmount kit for connecting the Host-to-EBM & EBM-to-EBM is different. Please contact your dealer for further details.

3000VA

Install the 3000VA series into 19" rack as shown below.

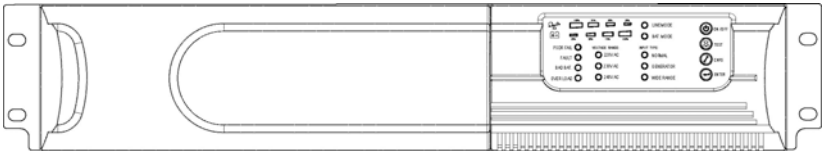

9. Turn on the UPS and connect the load.
10. After installing the UPS into rack, the load may be connected. Make sure the load equipment is turned off, then plug all loads into the output receptacle properly protected by a circuit breaker or fuse in accordance with national and local electrical codes.

4. INSTALLATION

10. Emergency Power Off(EPO) set up

1500/2000VA and 3000VA include EPO port that allows power to be shut down the protected equipment immediately and does not follow the shutdown procedure from any power management software.

Note: When EPO switch is reset, the equipment will not return to battery power until the UPS is manually restarted. If pressing power switch to turn off UPS after EPO is activated, the UPS remains in Standby mode when restarted until pressing power switch to turn on the UPS again.

Follow the procedure to install the EPO switch as below.

1. Check the UPS is turned off.
2. Remove the EPO connector from the EPO port on the rear panel of UPS
3. Connect isolated, normally-open, dry contacts (rated to handle 60Vdc maximum, 30Vac RMS maximum, and 20mA maximum) across the EPO device to Pin 1 and Pin 2. Use non-shield wiring, size 18-22 AWG ($0.75 \text{ mm}^2 - 0.3 \text{ mm}^2$).
4. Reconnect the EPO connector to the EPO port.
5. Verify that the externally-connected EPO switch is not activated to enable power to the UPS output receptacles.
6. Plug in the UPS, then pressing power switch  button to turn on the UPS.
7. Activate the external EPO switch to test the EPO function
8. De-activate the external EPO switch and restart the UPS.

5. ADDITIONAL BATTERY INSTALLATION SETUP

1500/2000VA and 3000VA include external battery port that allow to provide additional battery runtime. 1500/2000VA model has no internal battery, and 3000VA has designed an internal battery inside the UPS.

Caution: Connecting battery cable to external battery port may occur sparkle if adding up additional battery.

Follow the procedure to install additional battery as below.

5. ADDITIONAL BATTERY INSTALLATION SETUP

1500/2000VA

There are two external battery ports for each side of UPS itself and battery pack.

1. Connect the battery cable to the external battery port of the rear of UPS.
2. Then connect the supplied battery cable from extended battery module to the external battery port of the rear of previous UPS.
3. If continuing to add up extended battery pack, repeat above steps.

- **Additional battery connection in rack form**

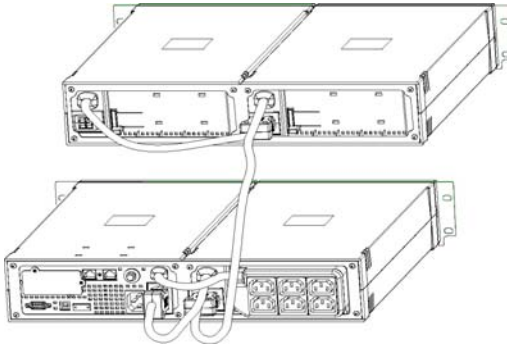

- **Additional battery connection in tower form**

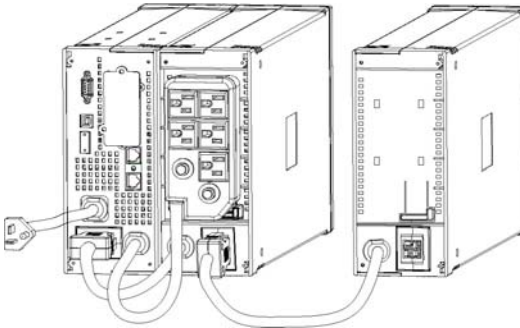

3000VA

There is one external battery port for the UPS itself.

1. Connect the supplied battery module cable from extended battery module to the external battery port of the rear of UPS.
2. If continuing to add up extended battery module, repeat above steps.

6. BATTERY REPLACEMENT

When the Bad Battery ^{BAD BAT.}  indicator flashes and there is a continuous sounding, the battery may need to be replaced. Please check the battery connection or contact your local dealer to order new battery.

CAUTION: A battery can present a risk of electrical shock and high short circuit current. The following precautions should be observed before replacing the batteries.

1. Turn off the UPS and disconnect the utility power cord from the wall outlet.
2. Remove rings, watches, and other metal objects.
3. If the battery replacement kit is damaged in anyway or shows signs of leakage, contact your dealer immediately.
4. Properly recycle or dispose of used battery. Do not dispose of batteries in a fire. The batteries may explode.

Note: If you are not qualified service personnel to replace the battery, do not attempt to open the battery door. Please call local dealer or distributor immediately.

Recycle the used battery:

- Never dispose the batteries in a fire. It may explode.
- Do not open or mutilate the batteries. Released electrolyte is harmful to the skins and eyes. It may be toxic. A battery can present a risk of electrical shock and high short circuit current.

To recycle properly the used battery, please do not discard the UPS, battery pack, and batteries into the trash bin. Please follow your local laws and regulations; you may contact your local recycling waste center for further information to dispose properly of the used UPS, battery pack, and batteries.

Follow the steps and Charts below to replace batteries:

750/1000VA

1. Unscrew and remove the front panel on both ends.



6. BATTERY REPLACEMENT

2. Disconnect the battery cable from the UPS and remove the battery retaining battery bracket.

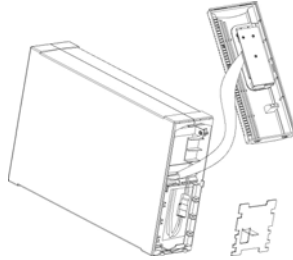

3. Grasp the battery and pull it out from the front panel.

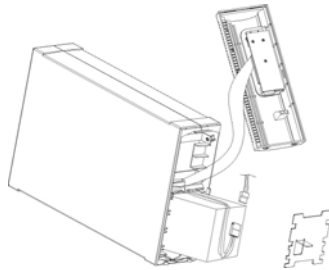

4. Slide the new battery into UPS
5. Reconnect the battery cable and screw up the battery retaining battery bracket.
6. Close and reinstall the front panel.

1500/2000VA

1. Remove the battery case (EBM) front panel by pulling on both ends.

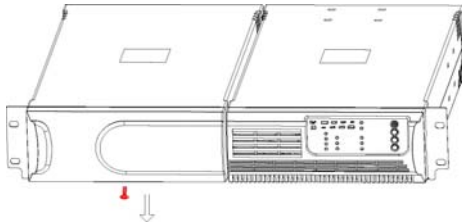

6. BATTERY REPLACEMENT

2. Disconnect the battery cable from the EBM.

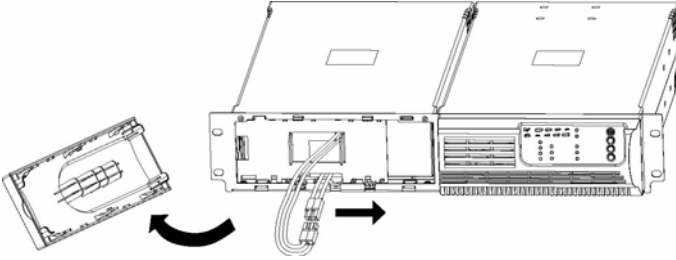

3. Unscrew and remove the battery retaining battery bracket.

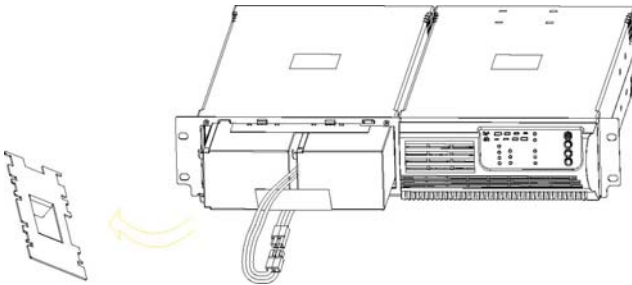

4. Pull the battery out onto a flat area.

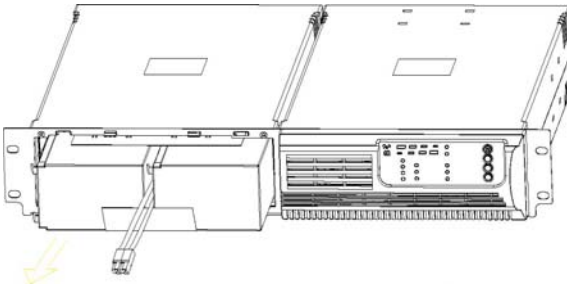

5. Slide the new battery into EBM.
6. Reconnect the battery cable and screw up the battery retaining bracket.
7. Close and reinstall the front panel back to EBM.

6. BATTERY REPLACEMENT

3000VA

1. Remove the battery case (EBM) front panel by pulling on both ends.

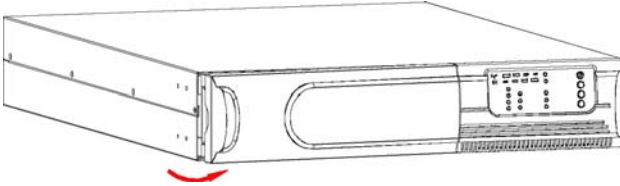

2. Disconnect the battery cable from UPS.

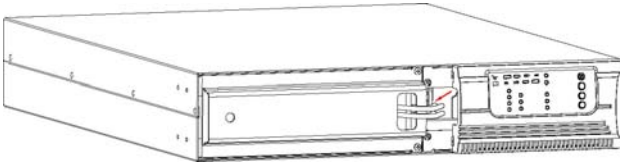

3. Unscrew the battery bracket from the EBM



4. Remove the battery bracket from EBM by pulling on both ends.

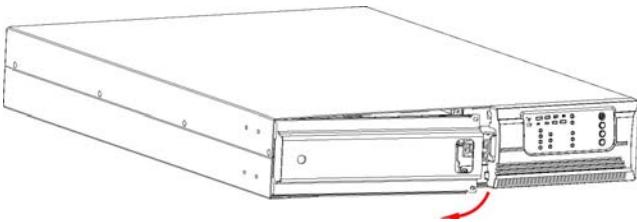

5. Pull the battery out (from right side) onto flat area.

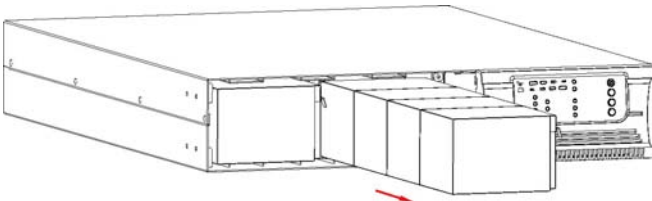

6. BATTERY REPLACEMENT

6. Pull the left side of battery out onto flat area.

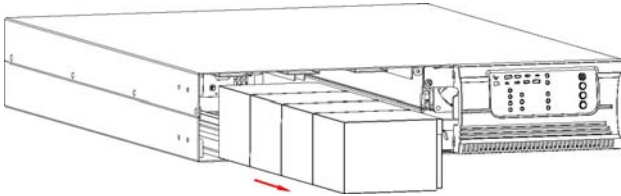

7. Slide the new batteries into EBM.
8. Reconnect the battery cable and screw up the battery bracket.
9. Close and reinstall the front panel back to EBM.

7. COMMUNICATION PORT

- 7.1 RS232 + Dry contact (750/1000/1500/2000/3000VA):

DB9 Female (RS232 +dry contact)

PIN #	Description	I/O	Function Explanation
1	Low Battery	Output	Low Battery Output (*normally open, pull to Pin#5 when battery low alarm in battery mode)
2	TxD	Output	TxD
3	RxD	Input	RxD
4	DTR	Input	(tied to pin 6)
5	Common	--	Common (tied to chassis)
6	DSR	Output	(tied to pin 4)
7	RTS	Input	No connection
8	AC Fail	Output	AC Fail Output (*normally open, pull to Pin#5 when UPS is in battery mode).

- 7.2 USB port: HID protocol

The USB and RS232 are unable to operate at the same time. Either only USB or DB9 can connect with RS-232 at one time, usually connecting with USB function is priority.

8. TROUBLE SHOOTING

Audible Alarm Trouble Shooting:

Problem	Cause	Solution
Sounding every 4 seconds	The UPS is on battery	Check the input voltage
Sounding every second	The battery is running low	Save your work and turn off your equipment
Continuously sounding	The UPS fails	Please contact your local dealer
Sounding every second	Output overload	Check load level indicator and remove some load
Continuously sounding	Battery may need to charge or service	Replace the battery

General Trouble Shooting:

Problem	Cause	Solution
The UPS is not on when power switch is pressed	The power cord is not connected correctly	Check the power cord connection
	The wall outlet may be faulty	Please contact your local qualified electrician
	The UPS output may short-circuit or overload	1. Disconnect all loads and ensure nothing is lodged in output receptacles 2. Ensure loads are not defective or shorted internally
	Internal fuse may be blown	Please contact your local dealer
UPS could not provide power to the load	Power presents on one output receptacle	Check the output fuse
	No output from any output receptacle	1. Check the connected cable 2. Ensure the load does not exceed the maximum rating of UPS
Battery has reduced backup time	Battery is not charged	Re-charge the battery at least 24 hours
	Battery may not able to hold a full charge due to age.	1. Recharge the battery at least 8 hours 2. Replace Battery
The UPS fault LED lights on	The UPS fails	Save your work and turn off equipment. Please contact your local dealer
Connected equipment's lose power while connected to the UPS	The UPS may be over- loaded	Check the load status
	The UPS may be failed	Please contact your local dealer
The UPS is beeping continuously	The UPS is in fault condition	Check the audible alarms condition table
Buttons does not work	1. The UPS is in green mode 2. Button is Broken	1. Wait for a while and try again 2. Please contact your local dealer

9. SPECIFICATION

MODEL		750/1000VA	1500/2000VA	2880VA
CAPACITY	Watt	500W/700W	975W/1300W	2100W
INPUT	Voltage	110/120/127VAC or 220/230/240VAC		
	Voltage Range	Acceptable Voltage Range	0-160VAC / 0-300VAC	
		Line Low Transfer(Wide mode)	77/84/89VAC \pm 4% or 154/161/168VAC \pm 4%	
		Line High Transfer	132/144/152VAC \pm 4% or 264/276/288VAC \pm 4%	
	Frequency Range	50/60Hz \pm 5Hz for Normal Mode; >40Hz for Generator Mode		
	Surge Rating (LV/HV)	320 / 230 Joules	430 / 250 Joules	500 / 640 Joules
OUTPUT	Voltage	110/120/127VAC or 220/230/240VAC		
	Voltage Regulation (Batt. Mode)	\pm 5% RMS for entire battery voltage range		
	Frequency	50Hz or 60Hz		
	Frequency Regulation (Batt. Mode)	\pm 0.1Hz		
	Waveform	Pure Sinewave		
OVERLOAD RATING	Line Mode	110% -0%, +8%; shutdown after 3 minutes. 150% -0%, +10%; shutdown after 10 cycles		
	Battery Mode	110% \pm 6%; shutdown after 30 seconds. 120 % \pm 6 %; Shutdown after 5 cycles		
TRANSFER TIME	Typical	2-4ms Typical, 6 ms max ; 13ms max. for generator mode		
BATTERY	Battery Type*	12V/7Ah ; 12V/9Ah	12V/7Ah; 12V/9Ah	12V/5Ah
	Battery Number	2 pcs	4pcs	8 pcs
	Backup Time (at full load)	5 minutes min.		
	Recharge Time	4 hours to 90% after discharged	3 hours to 90% after discharged	

MODEL		750/1000VA	1500/2000VA	2880VA	
INDICATORS	AC Mode	Line LED lighting			
	Backup Mode	Battery LED flashing every 4 seconds			
	Site Fault	Site fault LED lighting (for 120Vac models)			
	Load/Battery Level	4-segment LED bar – 0 - 25%: 4 th LED lighting; 26% - 50%: 3 rd and 4 th LEDs lighting; 51%-75%: 2nd, 3rd, and 4th LEDs lighting			
		76% - 100%: 4 LEDs in a row all lighting			
	UPS Fault	Fault LED lighting			
	Overload	Overload LED lighting			
	Low Battery	Battery LED flashing every second			
AUDIBLE ALARM	Backup Mode	Sounding every 4seconds			
	Low Battery	Sounding every seconds			
	UPS Fault	Continuously Sounding			
	Overload	Sounding every second			
	Battery Replacement	Sounding every second			
PHYSICAL	UPS Case	Dimension (WxHxD) mm	235*86.2*383	217*86.5*413.5	438*86.2*582
		Net weight (kg)	750VA: 10.6/ 1000VA: 10.7	6.5	34.1
	Battery Case	Dimension (WxHxD) mm	N/A	217*86.5*413.5	438*86.2*582
		Net weight (kg)	N/A	11.5	41.1
ENVIRONMENT	Operating Environment	0- 40°C, 0-90 % relative humidity (non-condensing)			
	Noise Level	Less than 45dB			
INTERFACE	RS-232	Support Windows Family, Linux, and Mac			
	Dry-Contact	Yes	Yes	Yes	
	USB	Yes	Yes	Yes	
	SNMP	N/A	Optional	Optional	
	EPO	N/A	Yes	Yes	

10. SOFTWARE INSTALLATION

WinPower is a brand new UPS monitoring software, which provides user-friendly interface to monitor and control your UPS. This unique software provides safely auto shutdown for multi-computer systems while power failure. With this software, users can monitor and control any UPS on the same LAN no matter how far from the UPSs.

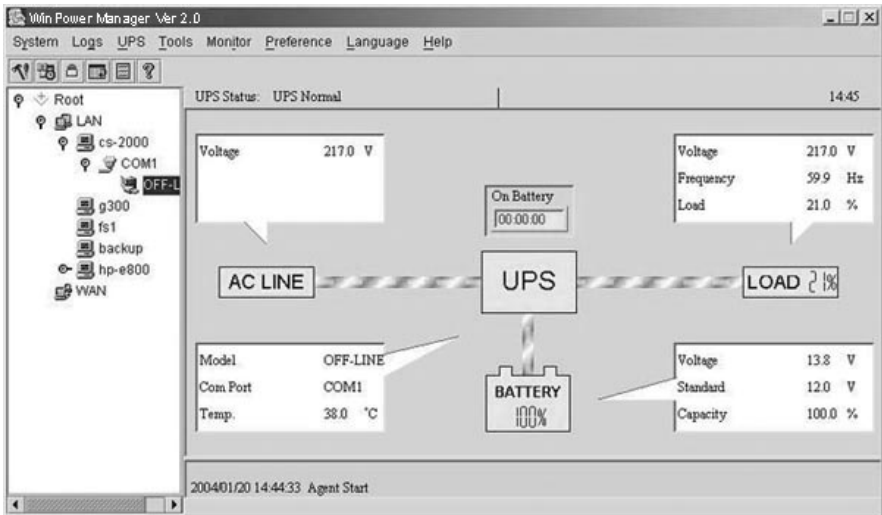

Installation procedure:

1. Go to the website: <http://www.ups-software-download.com/winpower.htm>
2. Choose the operation system you need and follow the instruction described on the website to download the software.
3. When downloading all required files from the internet, enter the serial No: 511C1-01220-0100-478DF2A to install the software.

When your computer restarts, the WinPower software will appear as a green plug icon located in the system tray, near the clock.

